

PIPE EXPANSION JOINTS



Movement Absorption

Pipe expansion joints provide axial movement absorption and maintain the pipeline security. A heating pipeline system at 90/70°C causes approximately 3 mm of movement for each floor of the buildings. For the buildings higher than 10 floors, use of the pipe expansion joints becomes compulsory in order to absorb total expansion amount. Pipe expansion joint application must be repeated for each section between 8-10 floors.

Advantages of Pipe Expansion Joints

- They prevent damage to pipelines result of the line movements
- They absorb the possible noises and provide convenience for the users
- They are installed easily and provide time and money saving
- They have a compact and decorative design that reduces the waste of space
- They help to protect equipment from stress due to misalignment

Application Areas

- HVAC piping lines

DESIGN (EN 14917)

Body	Aluminium external pipe or Stainless steel (optional)
Bellow Material	Stainless Steel AISI 316L & 321
Connection Types	Welded Ended & Threaded
Inner Sleeve	Built in internal pipe (St 37.2) operates like inner sleeve

Operation Conditions

Operating Temperature	-10°C/+100°C
Operating Pressure	Standard pressure rating is PN16 Can be produced with different pressure rates PN corresponds to the allowable operating pressure at room temperature

Important

Standard models are produced as un-restrained, fixed points should be created as to withstand springing force as well as pressure thrust caused by the system pressure. For detailed information, get in contact with Ayvaz's expert sales team. We strongly advise against the use of expansion joints and bellows for misalignment. Torsion on bellow parts are not desirable and should be eliminated.

PIPE EXPANSION JOINTS

Threaded, Pipe Expansion Joints			
Type	Movement	Available Size (inch)	Pressure Class (PN)
BKD-50	50mm (-45/+5)	1/2"-2"	16
	50mm (-35/+15)	2½"-5"	

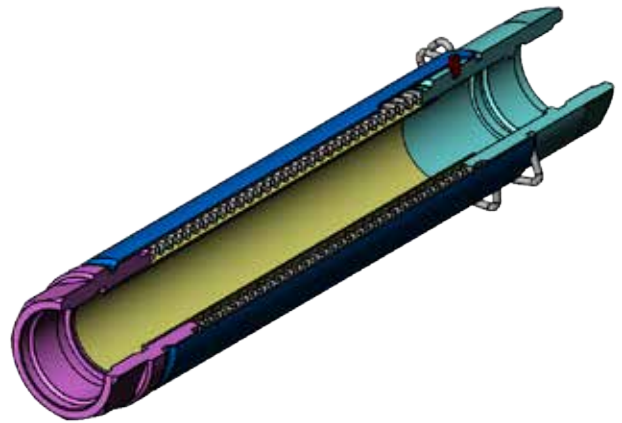
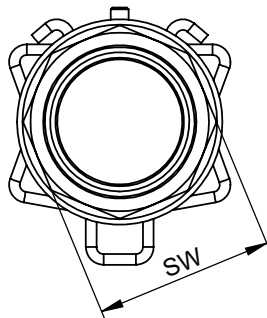
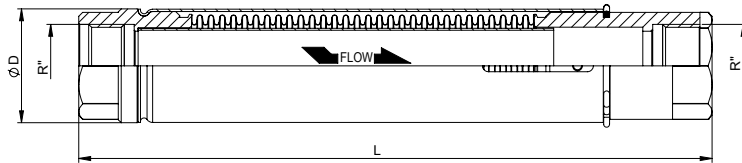

Bellows Information					ØD	SW	L
Size	Inner Diameter	Axial Movement mm	Effective Area cm ²	Axial Spring Rate N/mm			
1/2"	21,3	+5/-45	7,5	18	38	32	290
3/4"	26,9	+5/-45	7,5	18	38	32	290
1"	33,7	+5/-45	11	16	48	41	285
1 1/4"	42,2	+5/-45	17,8	19	60	50	320
1 1/2"	48,3	+5/-45	26	22	75	65	320
2"	60,3	+5/-45	26	22	75	65	320

* All the dimensions in the table are given in "mm".

** Subject to technical alterations and deviations resulting from the manufacturing process without giving any notification.

Reduction Factors for Pressure			
Temperature °C	Reduction Factor Kp	Temperature °C	Reduction Factor Kp
20	1,00	350	0,64
100	0,85	400	0,63
150	0,81	450	0,62
200	0,77	500	0,60
250	0,71	550	0,59
300	0,68	600	0,57

Pressure reduction factor

The reduction factor is used to define the design pressure [PS] where temperatures exceed 20 °C. It compensates for the decay in material mechanical properties at elevated temperatures. The calculated pressure is lower than the nominal pressure of the standard item.

Calculation: $PS \leq PN \times Kp$

PIPE EXPANSION JOINTS

Welded Ends, Pipe Expansion Joints			
Type	Movement	Available Size (DN)	Pressure Class (PN)
BKKB-50	50mm (-45/+5)	15-50	16

Welded Ends, Pipe Expansion Joints			
Type	Movement	Available Size (DN)	Pressure Class (PN)
BKKB-50	50mm (-35/+15)	65-150	16

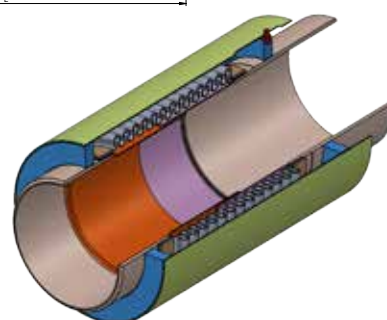
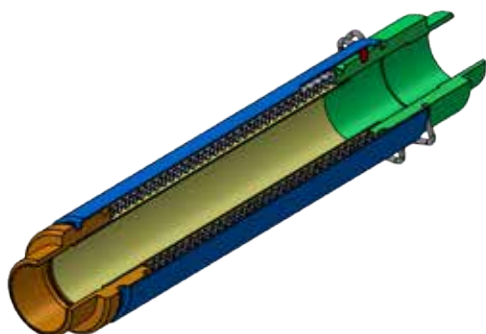
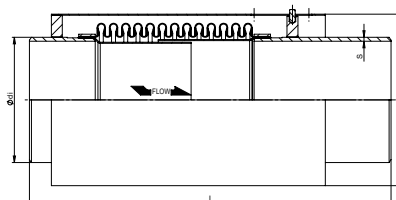
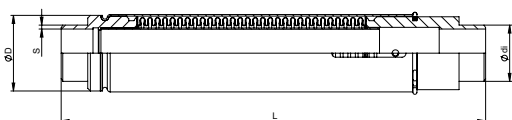

Bellows Information					ØD	S	L
Size	Inner Diameter	Axial Movement mm	Effective Area cm ²	Axial Spring Rate N/mm			
DN15	21,3	+5/-45	7,5	18	38	2,5	290
DN20	26,9	+5/-45	7,5	18	38	3	290
DN25	33,7	+5/-45	11	16	48	3	285
DN32	42,2	+5/-45	17,8	19	60	3	320
DN40	48,3	+5/-45	26	22	75	3	320
DN50	60,3	+5/-45	26	22	75	3	320
DN65	76,1	+15/-35	57,5	65	107	2,9	330
DN80	88,9	+15/-35	78,5	91	127	3,2	330
DN100	114,3	+15/-35	126,7	148	158	3,6	330
DN125	139,7	+15/-35	181,1	199	180	4	330
DN150	168,3	+15/-35	266,4	213	220	4,5	400

* All the dimensions in the table are given in "mm".

** Subject to technical alterations and deviations resulting from the manufacturing process without giving any notification.

Reduction Factors for Pressure			
Temperature °C	Reduction Factor Kp	Temperature °C	Reduction Factor Kp
20	1,00	350	0,64
100	0,85	400	0,63
150	0,81	450	0,62
200	0,77	500	0,60
250	0,71	550	0,59
300	0,68	600	0,57

Pressure reduction factor

The reduction factor is used to define the design pressure [PS] where temperatures exceed 20 °C. It compensates for the decay in material mechanical properties at elevated temperatures. The calculated pressure is lower than the nominal pressure of the standard item.

Calculation: $PS \leq PN \times Kp$

THERMAL EXTENSION CALCULATION & EXPANSION JOINT SELECTION (DN15-DN50)

Min. Installation temperature= -10°C
 Max. Operation temperature= 95°C
 $\Delta t = 95 - (-10) = 105^\circ\text{C}$
 $K = \text{Thermal expansion coefficient for carbon steel pipes} = 0,012\text{mm/m}^\circ\text{C}$
 $S = 1,05$ (5% safety factor)
 $H = \text{max. floor height} = 3,3\text{m}$
 $N = \text{max. floor number} = 10$
 $\Delta L = \text{total thermal expansion} = K \times \Delta t \times (H \times N) \times s$
 $\Delta L = 0,012 \times 105 \times 33 \times 1,05 = 43,65\text{mm}$

Result: Total expansion of the pipe (44,49mm) must be absorbed by expansion joint that must have min. 44,49mm compression capacity. Using single Ayvaz pipe expansion joint with 50mm (-45/+5) axial movement capacity is sufficient enough to absorb total pipe's expansion.

Single Expansion Joint for The Buildings Up To 17 Floors

- Pipe line of the top 3 floors in not necessary to be fixed as the pipe & branch equipment like elbows, tees etc... would be sufficient to absorb the expansion. Similarly, 4 floors from the bottom do not require the use of expansion joint as the main connection at the basement (not fixed) would slide upward and downward to withstand the thermal movement.

- This basically means that the use of expansion joints for the buildings with less than 7 floors is not necessary.

- Thermal movement of the pipes of the buildings up to 17 floors is possible by using single Ayvaz expansion joint.

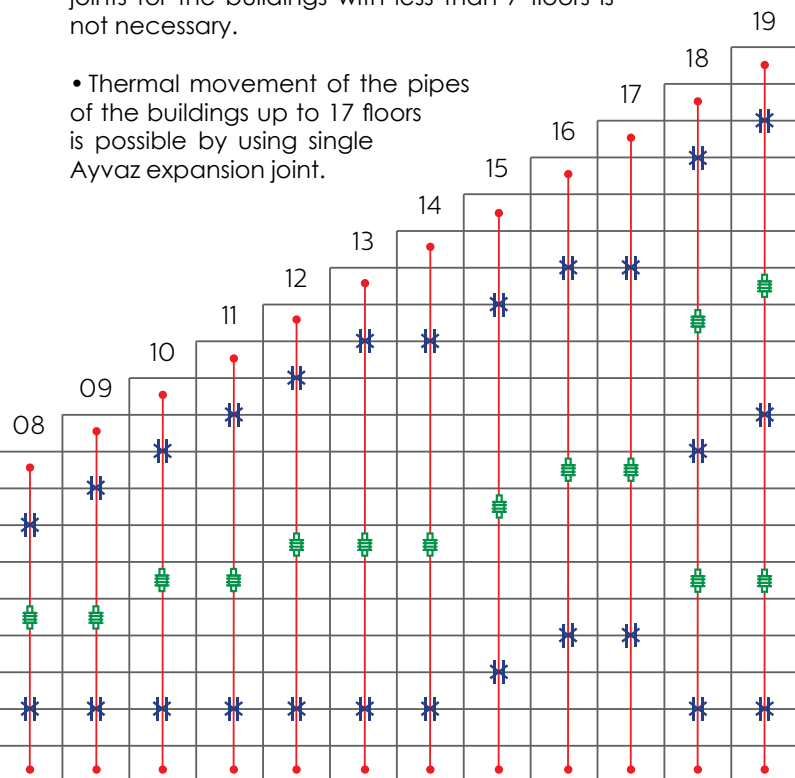
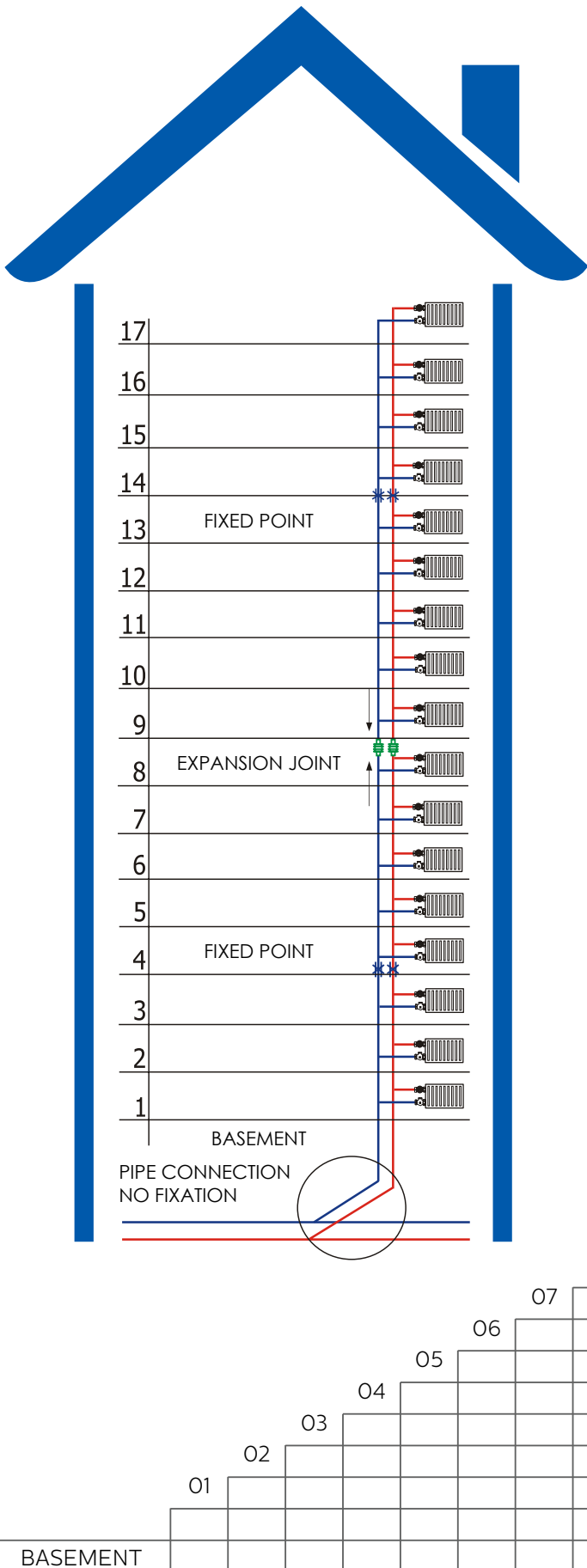



PIPE EXPANSION JOINTS

AYVAZ PIPE EXPANSION JOINTS BUILDING INSTALLATION SCHEME

HEATING LINE FOR CARBON STEEL PIPELINES FOR BUILDINGS WITH 8-40 FLOORS

Dimensions : DN15-DN50
 Total Axial Mov. Capacity : 50mm (45mm comp/5mm ext.)
 Max. Operating Pressure : 16 bar
 Floor Height : 3-3,3m
 Operating Temperature : 95°C
 Min. Ambient Temperature : -10°C

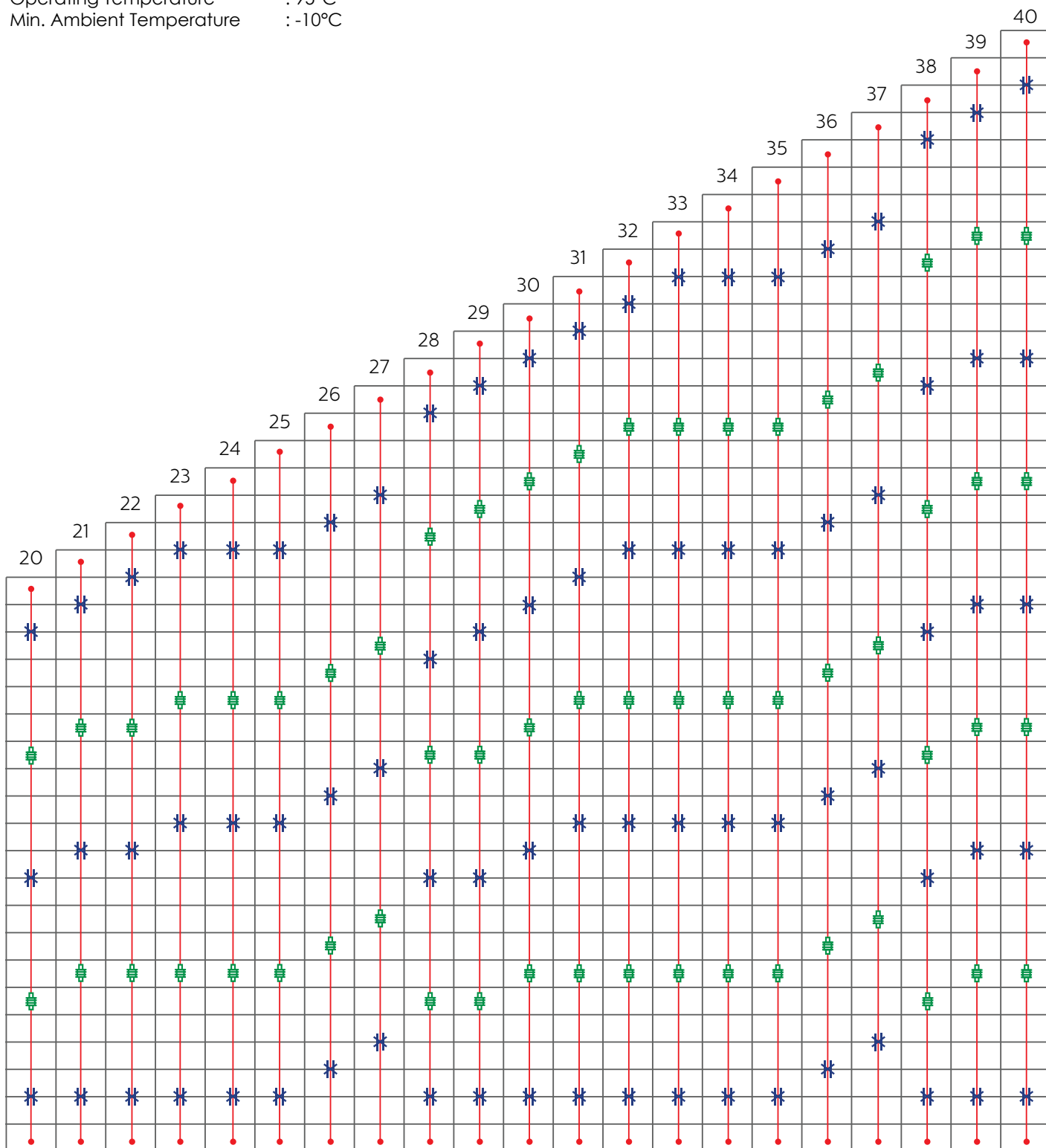

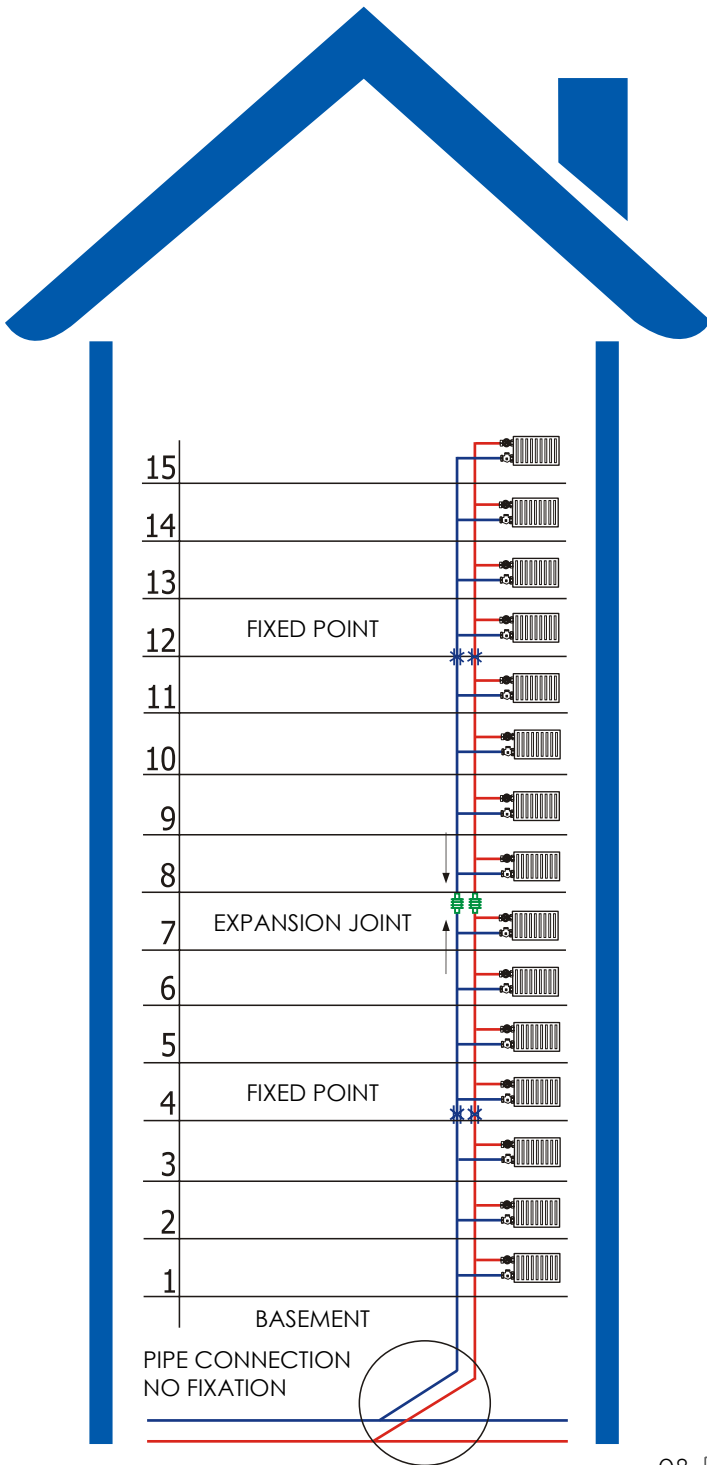

THERMAL EXTENSION CALCULATION & EXPANSION JOINT SELECTION (DN65-DN150)

Min. Installation temperature= -10°C
 Max. Operation temperature= 95°C
 $\Delta t = 95 - (-10) = 105^\circ\text{C}$
 $K =$ Thermal expansion coefficient for carbon steel pipes= 0,012mm/m°C
 $S = 1,05$ (5% safety factor)
 $H =$ max. floor height= 3,3m
 $N =$ max. floor number= 8
 $\Delta =$ total thermal expansion= $K \times \Delta t \times (H \times N) \times s$
 $\Delta L = 0,012 \times 105 \times 26,4 \times 1,05 = 34,92\text{mm}$

Result: Total expansion of the pipe (34,92mm) must be absorbed by expansion joint that must have min. 34,92mm compression capacity. Using single Ayvaz pipe expansion joint with 50mm (-35/+15) axial movement capacity is sufficient enough to absorb total pipe's expansion.

Single Expansion Joint for The Buildings Up To 15 Floors

- Pipe line of the top 3 floors in not necessary to be fixed as the pipe & branch equipment like elbows, tees etc... would be sufficient to absorb the expansion. Similarly, 4 floors from the bottom do not require the use of expansion joint as the main connection at the basement (not fixed) would slide upward and downward to withstand the thermal movement.

- This basically means that the use of expansion joints for the buildings with less than 7 floors is not necessary.

- Thermal movement of the pipes of the buildings up to 15 floors is possible by using single Ayvaz expansion joint.

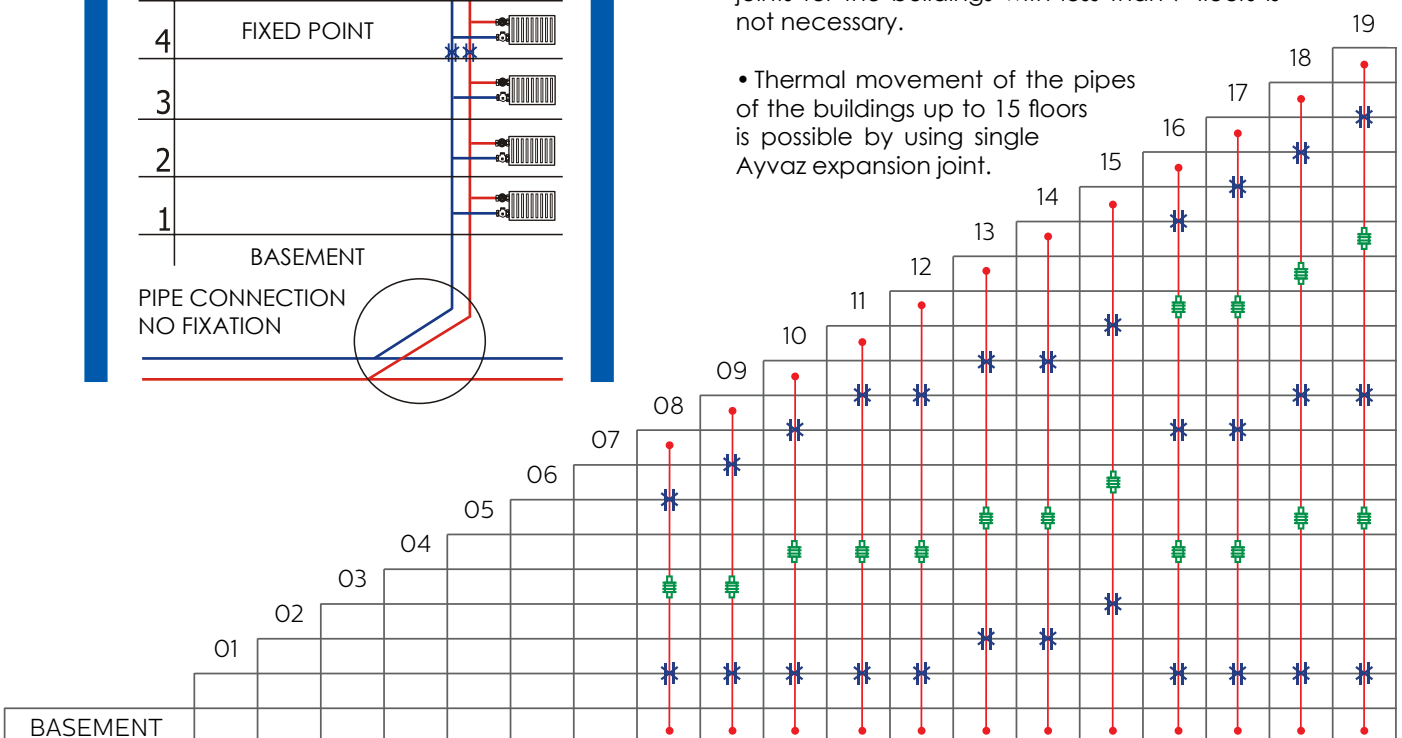



PIPE EXPANSION JOINTS

AYVAZ PIPE EXPANSION JOINTS BUILDING INSTALLATION SCHEME

HEATING LINE FOR CARBON STEEL PIPELINES FOR BUILDINGS WITH 8-40 FLOORS

Dimensions : DN65-DN150
 Total Axial Mov. Capacity : 50mm (35mm comp/15mm ext.)
 Max. Operating Pressure : 16 bar
 Floor Height : 3-3,3m
 Operating Temperature : 95°C
 Min. Ambient Temperature : -10°C

